

Pressure Relief Valve for Solar Systems 8115

for the protection of solar collectors and for special applications



7

Field of application

The pressure relief valve type 8115 is used as a protection for solar heating systems. It can be used for the protection of other hydraulic systems as well.

The table indicates the required connection size in accordance with the collector size.

Design

The operational parts in the pressure relief valve type 8115 are protected against direct contact with the medium (protection against corrosion). The

pressure relief valve 8115 can be lifted by means of the rotatable handle.

8115 Pressure relief valve Solar

Materials

The body is made of high-quality low-lead brass; the spring cap is made of zinc die-casting. The diaphragm and the seat are made of heat and

ageing resistant synthetic material and the spring of corrosion protected spring steel wire.

Installation

There shall be no obturators or narrows in the connecting pipe between the solar collector group and the pressure relief valve. Pipe bends shall have a bend diameter of at least 3xD (pipe diameter) in the centre line of the pipe. There is no restriction for intrinsically safe installations as regards the length of the connecting pipe. An adequate arrangement of the connecting pipe should prevent the formation of dirt within the pipe. The relief pipe of the pressure relief valve shall not freeze up and the

accumulation of water in it shall be prevented. The outlets of the relief pipe have to be located in such way that the heat transfer medium coming out of the pressure relief valve can be drained under visual control and without presenting any danger. When antifreezer is added to the water and the boiling point of the antifreezer is above the boiling point of the water, the relief and drain pipes shall end in an open container that is capable of holding the complete volume of the collectors.

Thoroughly rinse the pipe prior to installation. Install the pressure relief valve under considerati-

on of the flow direction (see arrow on the body) in compliance with the instructions.

Technical data

Operating temperature:

max. 160 °C

Opening pressure:

2.5 bar, 3.0 bar, 4 bar and 6 bar

Mounting position:

preferably main axis vertical,
inlet connection pieces facing downwards

Fluids:

water, neutral non-adhesive fluids,
blend of glycol and water up to a mixture
ratio of 1 : 1

Components approval number:

TÜV-SV-10-1127-SOL-50-p

Serial number:

8115...

CE 0085

Maintenance

The correct function of the pressure relief valve should be checked by qualified personnel at initial operation: turn the lifting handle in the direction of the arrow until you hear a click. Afterwards, the valve has to be closed tight. Should the valve

drip constantly, it is very likely that impurities have built up in the seat. To clean the valve seat and seal, unscrew the head part. After cleaning, refit the head part; the opening pressure remains unchanged after this operation.



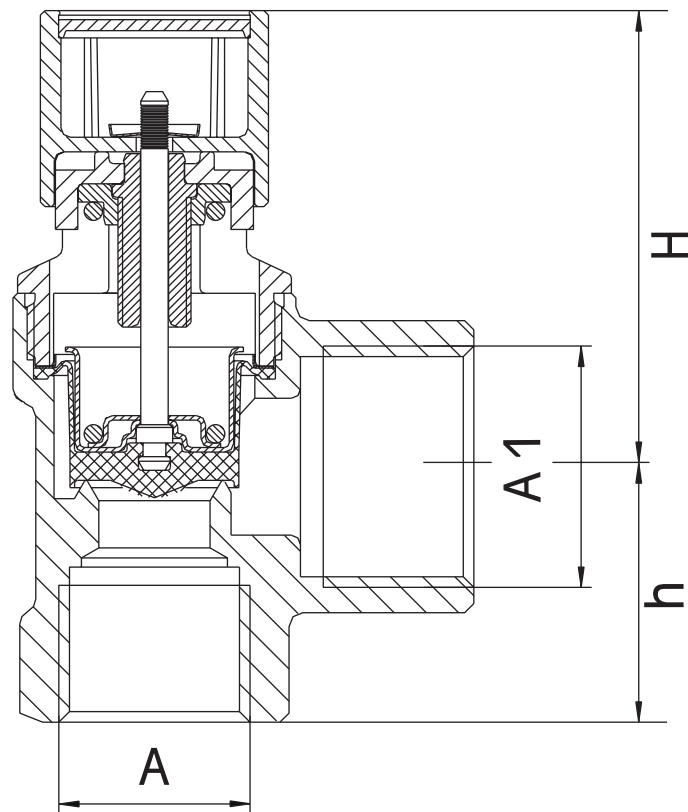

7

Nominal size		DN 15	DN 20
	A	R 1/2"	R 3/4"
	A 1	R 3/4"	R 1"
Dimensions in mm	H (mm)	50	52
	h (mm)	28	34
Size of Collector	m ³	bis 50	bis 100

Designs

Special sizes up to DN 50 on request

8115 Pressure relief valve Solar

Components / Order numbers

①

Head part

DN 15:

2,5 bar: 8115.15.000

3,0 bar: 8115.15.001

4,0 bar: 8115.15.002

6,0 bar: 8115.15.003

DN 20:

2,5 bar: 8115.20.000

3,0 bar: 8115.20.001

6,0 bar: 8115.20.002

②

Body

